

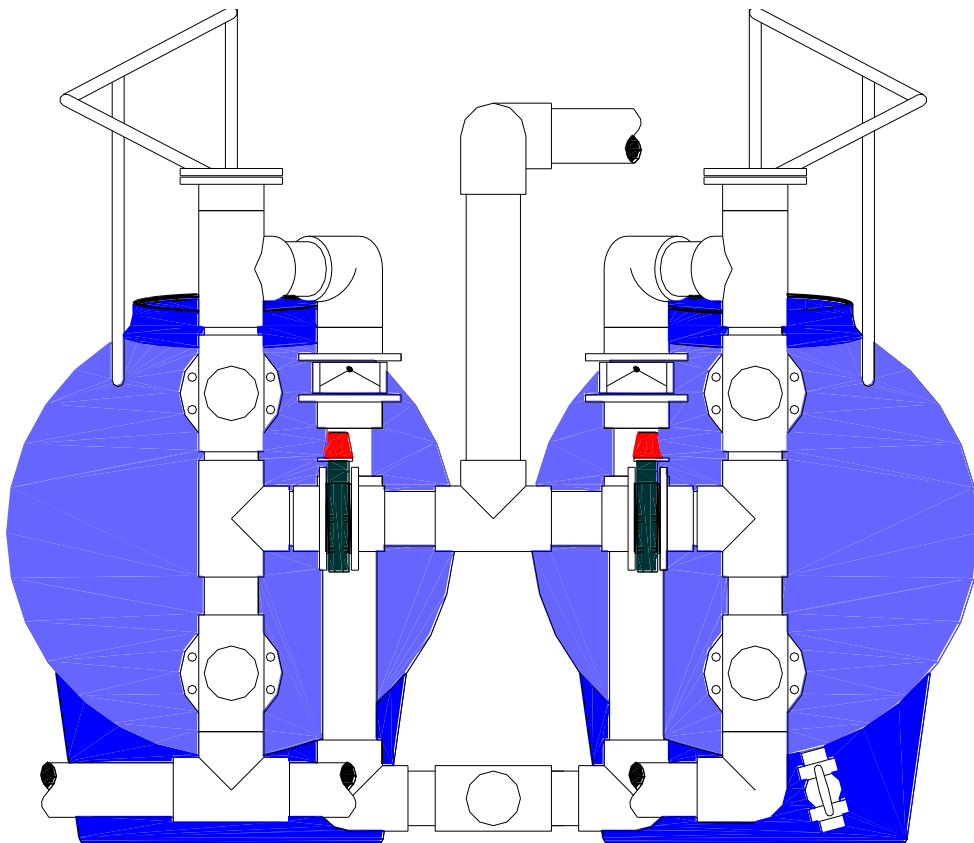

# INSTALLATION & OPERATING MANUAL

## “Tandem Filter Installation with CGF Multiport Valves”



## CHADSON GRANULAR FILTERS

Perth : 15 Cressall Road, Balcatta, WA 6021 – Phone (08) 9344-3611  
Sydney : 162 Beaconsfield Street, Milperra NSW 2214 – Phone (02) 9772-2477

[www.chadsonfilters.com.au](http://www.chadsonfilters.com.au)

## PREFACE

Congratulations on your purchase of a CGF filter. This product is designed & made in Australia specifically for Australia's harsh conditions. Providing that the product is installed and operated according to Instructions it will provide many years of reliable service. Please take the time to read & understand these Instructions before commencing work or starting-up the filter system. This will help you obtain all of the benefits and the features that are built into this product. Prior to the proposed handover date, the Installer should issue this Booklet to the Pool Operator with any other information that he may be required to provide.

These Instructions supersede all previous information and are effective from January 2004. The information provided within this Document is the property of Chadson Granular Filters (CGF) and it is subject to Copyright that prevents it from being copied, modified, or used for any purpose other than originally intended.

## RECORD THIS IMPORTANT INFORMATION

Original Equipment Purchaser (OEP)	
Purchase Date	
Filters Installed By (Name)	
Installers Contact Details	
Project Consultant (if applicable)	
Owners Name (or Project Name)	
Handover Given To (Operators Name)	
Handover Date	
Filter Models Supplied	
Filter Serial Numbers	
Certified Plant Capacity (m3/hr)	
Required BW Flow/Filter (l/sec)	
Replacement Media Required/Filter (kgs)	
Nearest Authorized Service Centre (ASC)	
ASC Contact Details	

### CGF FILTERS ARE PROUDLY "DESIGNED & MADE IN AUSTRALIA"

Given our commitment to provide the best possible information that is available, we welcome any comments & advice from Installers and or Operators. Send your comments & suggestions to [enquiries@chadson.com.au](mailto:enquiries@chadson.com.au)

## CONTENTS

Section	Topic	Page
1.	Introduction	4
2.	The Supply Scope	5
3.	Transport & Filter Handling	6
4.	What you need to Complete the Installation	6
5.	Filter Plant Design	6
6.	Filter Vessel Location	7
7.	Opening the Filter	9
8.	Re-Fitting Media Access Hatch	10
9.	Fitting the Backwash Valve	10
10.	Connecting the Remaining Pipework	11
11.	Fitting the Drain Valve	12
12.	Fitting the Kinetic Air Release/Vacuum Breaker	13
13.	Loading the Filter Media	14
14.	How It Works	15
15.	Filter Backwashing	16
16.	Start-up Pre-Requisites	17
17.	Initial Start-up	17
18.	Filter Operation	20
19.	The Backwash Procedure	20
20.	Disposal of Wash Water	21
21.	Operator's Duties & Responsibilities	22
22.	Application Problems	23
23.	Mechanical Damage of the Underdrain	24
24.	Problem Solving	24
25.	Backwash Valve – Trouble Shooting Guide	26
26.	Air Release/Vacuum Breaker – Trouble Shooting	26
27.	Water Chemistry Guide Lines	27
28.	Addenda (for additional or project specific information)	28

**1****INTRODUCTION**

- These Instructions refer to a tandem installation comprising two filters that are arranged in parallel with single lever multiport valves. Tandem filter systems are designed to “filter” at a rate of 21m<sup>3</sup>/hr/m<sup>2</sup> and be individually backwashed at the required rate of 42m<sup>3</sup>/hr/m<sup>2</sup>.
- The performance of your Chadson Granular Filter has been carefully ascertained and it has been proven in many similar applications.
- This product is required to be installed and commissioned by an accredited filtration contractor.
- These Instructions are generic by nature and they should be read in conjunction with a specific Data Sheet that relates to the filter nominated in the supply Contract.
- The tandem arrangement/concept described herein can apply equally to filters with filter areas greater than 3.5m<sup>2</sup>. In this cases commercially available (200mm diameter) valves would be required in lieu of the single lever valve that is described herein. For filters with 200mm connections Refer to Instructions #104 – Valve Matrix Instructions.
- Apart from the sheer simplicity of the single lever backwash valve, a “tandem” filter system provides all the filtration benefits that can be obtained with a conservative filter rate of 21m<sup>3</sup>/hr/m<sup>2</sup>. For details on other filter arrangements and different backwash methods, refer to other CGF Instructions.
- The CGF single lever backwash valve that is described in these Instructions is currently available in two different sizes - either in a 100mm (4”) or 150mm (6”). The primary function of the single lever multiport valve is to simplify the backwash process and to reduce the chance of Operator error.
- In the “locked down” position the filter is in the “filter” mode; in the “raised position” the water flow through the filter is reversed for “backwash” purposes. In either the case, at least one valve outlet port is always open, albeit to the backwash system or back to the pool.
- Due to available valve sizes, these Instructions apply equally to Filter Models MHS1500, MHS1800, MHS2400, MHS3000, & MHS3500. Reference to product data sheets will provide specific information on the physical dimensions, the valve size, the media requirements, the required backwash flow, the service weight, etc.,. If in any doubt; refer to the specific Data Sheet.
- Whilst not necessarily depicted by any diagrams, these Instructions may also apply to vertical filter vessels (with single lever multiport valves) that provide a filter area of up to 3.5 square meters.
- Larger filter requirements can also be accommodated by using a given number of tandem arrangements on the same pool.
- Unless certified otherwise, the filters outlined within these Instructions shall be used for commercial swimming pools using either fresh or salt water. Other uses (such as aquaculture, aquariums, equine pools, and industrial applications) may be subject to specific Instructions and different operating requirements.
- Do not connect any standard filter models to high water pressure or city water supply. Custom-made filters are specifically available for this purpose.

- Keep the filter label in good condition. Be sure to obtain a replacement label, if you discover that the filter label is missing or damaged.
- Record your filter's serial number in a suitable asset register. You will need this serial number to obtain future service and or spare parts.
- Trapped and compressed air inside a pressure vessel can cause serious damage and other risks - ensure that all air is out of the system before testing and or operating the system. Conversely, excessive vacuum may cause implosion – install the vacuum breaker and any other devices that are necessary to ensure that the filter is not subject to vacuum, excessive pressures, or sudden surges (water hammer).
- The excessive use of chemical flocculants may clog your granular filter. Use chemical flocculants judiciously and do not exceed the recommended dose rates.
- If fitting a “salt water chlorinator” (or any other similar device) great care must be taken to ensure that the appliance is installed in strict accordance with the manufacturer's Instructions and any local Standards and Codes that may be applicable.
- Salt-water chlorinators must have some form of “gas trap” or safety device. Failure to adequately address these requirements could affect your safety and result in serious damage.
- When installed and operated according to instructions, the Original Equipment Purchaser (OEP) is provided with a Warranty that the product is free from manufactured defects.
- This product requires regular service and maintenance. This work must be undertaken by an Authorised Service Centre (ASC) using genuine Chadson spare parts.
- Do not operate or change any plant or equipment settings, unless suitably trained or qualified. Any operational problems, water leaks, or anomalies must be reported and attended to as soon as they become apparent.
- Improper or negligent operation of a filter plant can result in costly damage to numerous system components. It is essential that the installed filter plant be correctly operated and maintained at all times. Product Warranty is conditional upon correct installation & operation.

## **2 THE SUPPLY SCOPE**

The components supplied with this filter system are as follows: -

- Two filter vessels (for each tandem system) as defined by Data Sheet or Supply Contract.
- One Kinetic air release / vacuum breaker/pressure gauge assembly for each filter.
- One Screened Drain Cock assembly for each filter.
- One Single lever backwash valve assembly for each filter.
- Drilled uPVC valve flanges, gaskets and bolts (for mounting of the backwash valve to each filter).
- Installation & Operating Instructions.

Check that all components have been delivered and that there are no signs of obvious transport damage. Read the identification label that is fixed to each filter and confirm compliance with the supply Contract. Report all claims in writing within seven days of the delivery date.

Note that the valve orientation (ie., the direction of the soiled water inlet and the backwash outlet) is established at order time to suit a specific installation requirement. Refer to CGF for possible “valve orientation” options and note that automatic valve actuators are also available upon specific request.

Subject to the specific Contract details, interconnecting plumbing & additional piping (or plant) may also be included within the agreed supply scope. Filters may also be supplied with selected options that include air scour provisions, high-pressure rating, etc., Refer to the Supply Contract for specific details.

### **3 TRANSPORT & FILTER HANDLING**

“Delivery” and “the point of delivery” are as determined by the supply Contract.

To protect the product from transport grime and dirt, CGF filter vessels are wrapped in bubble wrap. This wrapping should be removed from the vessel when it first arrives at site. If left in direct sunlight for long periods of time (particularly during the hot summer months) this wrapping could melt, and it could adversely affect the exterior finish of the filter. The timber board on the filter’s inlet and outlet should be left in place until the installation time. This will reduce the risk of foreign materials entering the filter vessel.

Single lever backwash valves are individually crated for transport. These crates will include a carton that contains the sundry components (such as drilled flanges, gaskets, bolts, kinetic air release / vacuum breaker, screened drain cock assembly, Instructions, pressure gauge, etc., ).

The shipping weight of individual filters is as nominated on the relevant data sheets. Whilst some of these weights do not necessarily preclude man handling, on no account should the vessel be moved or lifted via the filter’s inlet and outlet connection. Horizontal filters are best moved into position by using a forklift (with extended tynes) or a lightweight (floor) crane using canvas type slings located under the belly of the filter.

Subject to their diameter, vertical type vessels may be supplied strapped to a timber transport pallet. Vertical filters (larger than 1500 mm diameter) are supplied with lifting lugs. Do not roll vertical vessels on their support skirt. Mechanical lifting plant must be operated in accordance with statutory requirements by trained and authorised staff.

### **4 WHAT YOU NEED TO COMPLETE THE INSTALLATION**

- A full understanding (and job experience) with all of the procedures that are necessary to install “mechanical piping systems”. These Instructions are not intended to provide any detailed information on the joining of pipe & fittings, fabrication, installation of valves, etc., These requirements are deemed to be fully understood by the trade qualified Installer.
- A design, a diagram, or at least a sketch plan, detailing how the filter is to be arranged to suit the planned connection to the filtered water line, the soiled water line from the pump, and the wastewater line (to the backwash detention system).
- Copies of relevant project specifications, relevant Standards, Guidelines, and Codes that apply to mechanical plumbing, filtration, water treatment, and other related subjects.
- An adequate supply of all necessary pipe, fittings, and supports/brackets - to suit a material take-off that is best determined from the above design, diagram, or sketch plan.
- Standard consumables (such as Teflon tape, solvent cement, cleaning agents etc.,) a high quality torch, and all the tools required and expected for mechanical plumbing.
- The required quantity and grades of filter media conforming to the requirements of the AWWA B100 Standard. Note that CGF Data Sheets recommend the placement of a gravel substrate.

### **5 FILTER PLANT DESIGN**

In order to obtain optimum performance from your CGF filters it is important that the filter system be correctly designed and sized. If a specific filter model has not been specified, we suggest that you seek advice from a recognized Consultant. Alternatively, we recommend that you contact a representative of Chadson Granular Filter Systems for detailed advice and assistance.

The effectiveness of your installation will largely depend upon the use of an appropriate filter area in combination with an efficient backwash regime. Whilst “filter rates” may legitimately vary, the delivery of the mandatory 42m<sup>3</sup>/hr/m<sup>2</sup> backwash rate is the responsibility of the Installing Contractor.

The “total filter area” required for your project will vary according to the pool volume, the water depth, the type of application (indoor or outdoor pool) water temperature, process design, turnover rate, and bather load. Given the extent of potential variables, the case history of other similar projects can be a very useful tool in assessing the load carrying capacity of a specific plant. Subject to specific details being provided, CGF will provide advice on filter sizing and possible options. Various classes of engineering drawings are also available upon request.

Due to current available valve sizes, these Instructions relate to single vessels that have filter areas between 1.5m<sup>2</sup> and 3.5m<sup>2</sup>. To cater for the requirements of larger projects, a given number of “tandem” filters may be arranged in parallel.

Alternatively, single filters with filter areas of up to 7.25m<sup>2</sup> are also available, albeit that they would not be supplied with the CGF single lever valve that is described within these Instructions. For details on other filter arrangements and different backwash methods, refer to other CGF Instructions.

Whilst the filter’s maximum operating pressure is 175 kPa, an appropriate “system design” should provide a clean start-up pressure in the order of 40 to 70 kPa. Given that it is “flow that cleans pool water”, higher operating pressures do not provide any technical benefit. With appropriate design, the shut-off head of the recirculating pump should not exceed 20m head. CGF filters are pressure tested to 350 kPa (twice the recommended maximum operating pressure). If assistance in pump selection is required, do not hesitate in obtaining specialist advice.

To ensure that filter vessels are not subject to vacuum conditions, all downstream boost pumps must be electrically interlocked (with the main recirculating pumps) so that they cannot be operated unless there is an adequate water supply flowing through the filters.

The pumping arrangement for a tandem system is a matter of design and it may vary. The application engineering for tandem filter systems is however very simple. In the filter mode, the soiled water flow is simply divided between the two filters. When the filters require backwashing, individual filters are consecutively backwashed with the full duty of the pump.

Notwithstanding the pumping arrangement that may be provided, all recirculating pumps must be fitted with suitable pre-pump strainers that provide effective screening of solids that are larger than 4mm. Talk to CGF for further details on the range of pre-pump strainers & pump connectors that are available as standard production.

When planning your installation, be sure to provide adequate service clearances for the future replacement of filter media. Subject to specific conditions the service life of a conventional sand media may vary from 5 to 8 years. Suitable access must also be provided for the initial installation and the possible/future replacement the filter vessels.

## **6 FILTER VESSEL LOCATION**

For best performance locate the “tandem filter system” as close as possible to the pool and to the associated services, such as the pool’s balance tank, the system’s backwash tank etc., Refer to Section 20 for further details on the disposal of waste wash water.

Subject to the specific installation requirements, the filters may be installed above or below the pool’s water level. In either case, the relative invert levels (of the pool’s water level & the plant room floor slab) should be kept to a minimum. If the filters are a long way above water level or have long discharge lines to either the pool or the backwash detention tank, this has the capacity to develop excessive negative pressure (vacuum) inside the filter vessels. This can present a risk of filter “implosion” and as such it needs to be adequately addressed in the process design phase.

If located above the pool’s operating water level the recirculating pump may require a footvalve for “priming” purposes. In these cases, a “hartford loop” (in the filtered water return line) is also required to minimise the syphon effect that will “drain down” the filter when the recirculating pump is shut down. This loop must rise above the height of the filter vessel, or at least above the sand bed depth. Contact CGF for details on the range of available footvalves. If located below water level, isolation valves will be required for future filter servicing. When filters are installed below the pool water level, the system designer is required to ensure that the plant room is effectively drained under all possible conditions. The CGF filter warranty excludes any consequential water damage.

If the filters are to be installed within an open filter yard it is best to shade them from continuous and direct heat from the sun. Exposure to the elements may result in some discolouration and powdering of the outside surfaces of the filter. If this were to occur, it is recommended that the exterior surfaces of the filters be painted with a solar resistant acrylic paint (like Watty Solagard or equal).

**Figure 1 : Typical Tandem Layout**

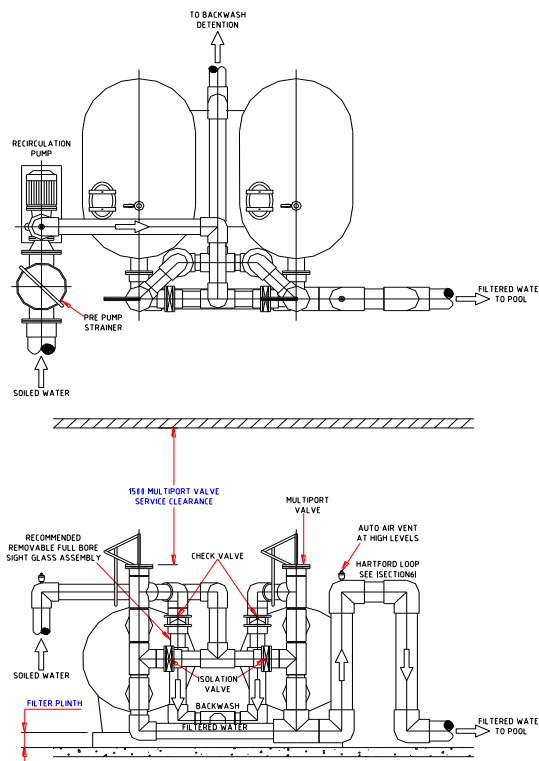

If the filters are to be installed within a building (or under an awning) sufficient head height should be provided to permit servicing of the backwash valve; specifically the possible removal of the valve shaft. If this is not practical, the three connections to the valve (ie., the soiled water inlet, the backwash outlet, and the filtered water outlet)



should be flanged, so that the valve can be physically removed from the filter vessel for servicing. This latter provision does not provide the same convenience, as providing the required height clearance for valve shaft removal.

The filters should be placed on a level concrete slab that is capable of supporting the full service weight of the filters (including its filter media and its water contents). The service weight of each filter is as detailed on the filters data sheets. Filters should be levelled-up (by using a spirit level) so that inlet & outlet flanges are square & true. If required, pack & grout the filters support skirt/cradle as required.

To provide the sufficient clearance to connect to the bottom of the backwash valve (ie., the filtered water outlet) the filter should be installed on a structural plinth (or a suitable support beam) that is sized to accommodate the diameter of the filtered water header. Where multiple tandem systems are used, the size of the parent line may be significant. Where planning a new installation the use of a recessed pipe service trench (in the plant room floor) should be considered.

Do not proceed to fill the vessel with filter sand at this stage. The filter media is best placed when the filters are installed and plumbed in their final position. No attempt should be made to move or re-position a filter vessel once it has been filled with media.

## 7 OPENING THE FILTER

Subject to the filter Model and the Supply Contract, the number and the type of media access hatch may vary.

When first opening the filter, it is essential that the elliptical cover plate (of the standard “inward opening” access hatch) be prevented from falling into the filter. Failure to observe this requirement could damage the filter’s underdrain. This type of accident is not covered by warranty and caution is required. Keep a tight hold of the manway cover during all of the following procedures: -

- (a) Slacken both hexagonal nuts that secure the davit clamps into position. Do not fully remove the nuts at this stage.
- (b) Remove one of the above nuts and remove one clamp completely.
- (c) Push access cover inwards to break the seal - note the second clamp will prevent the cover from falling into the filter.
- (d) Slacken the second nut further whilst holding the threaded stud (exposed by the removal of the first nut and clamp). Do not fully remove this nut, but take it to the end of the thread.
- (e) Whilst still holding threaded stud, twist second clamp to clear manhole, and push the access cover inwards.
- (f) Turn the access cover through 90° and remove it from the filter.
- (g) Check inside the filter for transit damage to the filter internals.

### NOTE !

Step (g) is an important procedure. Use a torch and carefully look for any loose or broken pieces. If any transit damage is noted, report this immediately to your filter supplier and do not proceed with the installation without obtaining further advice. Other types of CGF “round flanged” manway hatches are not subject to the same requirements. In either instance, do not leave the filter vessel open; when there is no reason for the filter to be open, refit the manway hatch as detailed in Section 8.

## 8 REFITTING THE MEDIA ACCESS HATCH

Reverse the procedure as outlined within Section 7. Ensure that the primary O-ring seal is clean and correctly

seated. Do not use any sealing compounds and do not over-tighten the hexagon nuts that secure the davit clamps into position. With the "inward opening" design, the internal operating pressure of the filter will assist the sealing arrangement of this standard hatch without the need for any over-tightening.

## 9 FITTING THE BACKWASH VALVE

- Loosely bolt the drilled flanges and the gaskets that have been supplied with the filter vessel as generally shown in Figure 2
- Cut stubs of uPVC pressure pipe to length that provides the required distance required from filter to the backwash valve. Whilst the backwash valve is customarily "close coupled" to the filter, some circumstances could dictate that it be installed remote from the filter. It could even be installed within a separate room.

**Figure 2 : Initial connection to the filter's flanges**

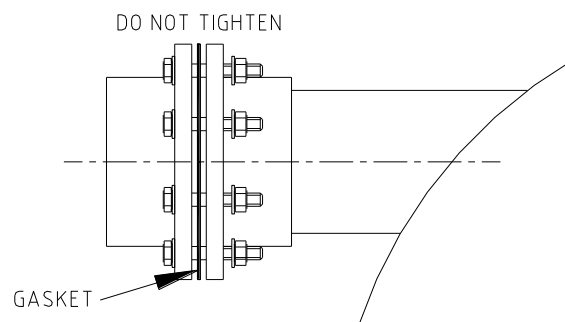

- Solvent cement the above pipe stubs into the backwash valve and ensure that any excess cement is removed from the inside and outside of the joint. It is important that no solvent cement enters the main body of the valve. See Figure 3.

**Figure 3 : Valve Connections**

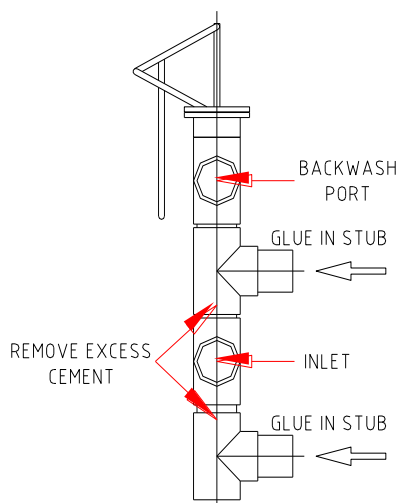

**Figure 4 : Fitting to Filter**

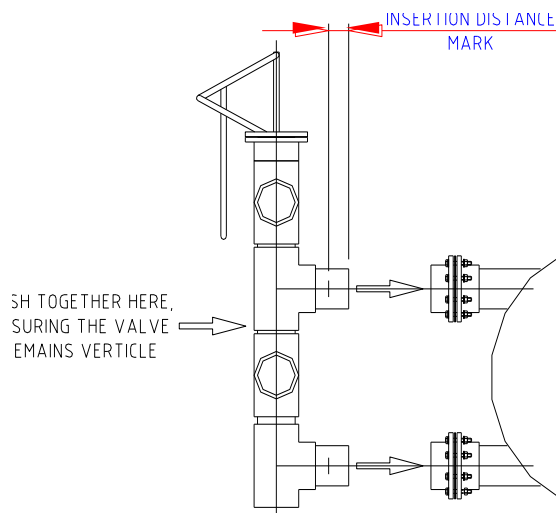

- In accordance with standard practice, mark stub pipes to indicate the distance that is required to ensure full insertion into the uPVC flange.
- Apply solvent cement to the loosely bolted flanges and the free ends of the stub pipes that have been glued into the valve. Immediately push the cemented parts together to make the glue joints that are shown above. Use a spirit level during this operation to ensure the valve is vertically aligned. Maintain pressure on joint for

approximately 5 minutes to ensure an effective glue joint. See Figure 4.

**WARNING !!**

When gluing flanges and pipes into the backwash valve, ensure that ALL excess solvent cement is removed from the inside of the valve. Excess solvent cement can cause fouling of the valve pistons and it lead to serious damage that is not covered by warranty. When the glue joints are set, tighten the flanges on the filter.

**10 CONNECTING THE REMAINING PIPEWORK**

Position the two filters adjacent to each other to best suit the intended installation requirements. As noted in Section 6, the filters should be installed and levelled-up on a suitable plinth. This will provide the clearance that is necessary to connect to the outlet sockets found at the bottom of the single lever multiport valves.

To permit individual backwashing (of each filter module) a suitable isolation/butterfly valve must be installed on the inlet side of each single lever multiport valve. The assembly sequence for connecting two filters in tandem may vary and as such, it is best determined by the installing contractor to suit the specific requirements.

Whilst individual backwash lines may be extended and connected to the proposed backwash system, a common waste line is also permitted. In this latter case, swing type check valves should be installed in the backwash line from each valve, prior to the connection into a common backwash line. It is recommended that a flanged sightglass or approved equal be installed in the backwash line. It is also advisable that backwash lines be installed to be self-draining. Ideally, the backwash piping should be extended to ground level at the first available opportunity.

**Figure 5 – Typical Multiport Valve Connections**

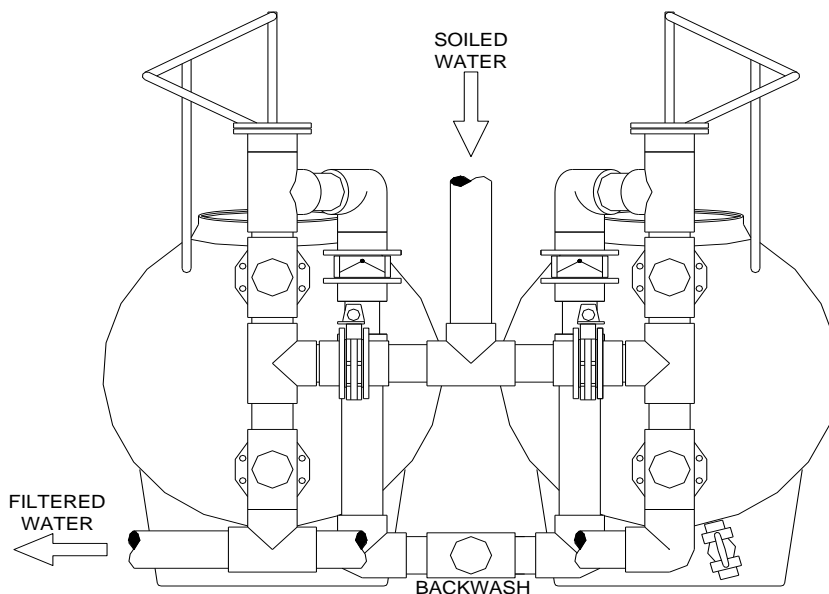

As stated in Section 6, if the filters are installed above the operating water level of either the pool or the balance tank, the parent filtered water line should incorporate a "Hartford loop".

All connecting pipework must conform to relevant plumbing codes. In accordance with "best Industry practice" all pipework should also be installed horizontally or vertically, in a neat and tidy manner. To avoid air locks, the Installer is required to provide suitable automatic air vents at all high points. It should be noted that "pipe fittings" reduce flow; for best efficiency, plan your installation to use the fewest possible fittings.

Connecting pipework must be supported independently of the filter vessel (and or the backwash valve) with suitable support posts and brackets. Details and spacing of pipe supports must satisfy relevant standards and recommendations provided by the supplier of the piping. With plastic piping systems adequate allowance must also be made for expansion and contraction. Refer to pipe supplier's literature for specific details.

uPVC pressure pipe (that is manufactured in accordance with AS1477) may be solvent welded direct into the sockets of the single lever multiport backwash valve. Adjoining flanges must be true and parallel to each other so that bolts are only used to make joints tight and not to pull flanges to true alignment. On no account should flanges be over tightened. To avoid stressing of the filter connections, all pipework, valves and fittings should be loosely hung in position to allow for general alignment. When all pipework is in generally position, the final tightening of bolts can be completed in a systematic and logical manner.

In accordance with normal Industry practise, pipework should be painted with approved gloss enamel that is applied as per the manufacturer's Instructions. Soiled water lines to the filter plant should be painted in a green colour; filtered water lines should be light blue, backwash lines should be dark brown. For more comprehensive details on painting & labelling refer to the requirements of AS-1318 and AS-1345.

## 11 FITTING THE DRAIN VALVE

The standard Drain Valve Assembly is designed to drain the filter vessel whilst retaining the filter sand. It is supplied ready to thread into the female bulkhead fitting that is found at the bottom of the filter vessel. Apply at least two layers of Teflon tape to the male thread of the Drain Valve and carefully screw this fitting into the 40 BSP bulkhead fitting. Get into a good/comfortable working position, and be sure not to cross thread the start of this connection.

### NOTE !

Do not use a pipe wrench, stillsons, footprints, multigrips, or other similar tool for tightening. Simply "hand tighten" to provide a "snug neat fit". Mechanical over-tightening can damage the threaded bulkhead fitting.

Figure 6: Screened Drain Valve (with 40BSP male thread)

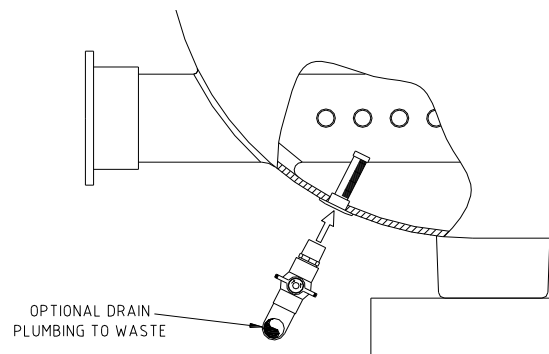

Notwithstanding the above warning, make sure that the screwed connection is watertight before placing the filter media. If this connection leaks under test; remove it, clean off all the sealant, re-apply new sealant, re-fit and re-tighten as instructed. If required, the outlet of the drain valve can be plumbed to divert "drain down water" to an adjacent floor waste or equal.

### WARNING !!

Whilst Silastic RTC 732 (by Dow Corning) may be used as an alternative to teflon tape, do not use other general purpose "pipe joining compounds". Many of these compounds are designed for "metal to metal" joints and they will create stress cracking on plastic components that is not covered by warranty. Unwarranted over-tightening will also void your warranty.

## 12 FITTING THE KINETIC AIR RELEASE/VACUUM BREAKER

The Chadson Kinetic Valve (CKV) is designed specifically for use with Chadson filters. When supplied and installed in accordance with Instructions, the CKV valve will effectively purge air that is trapped inside the filter(s). It will also provide automatic vacuum relief with a fast & effective response time. Amongst other things, these two functions are vital for the effective operation of the filters.

Figure 7 - Kinetic Valve Assembly

### CHADSON KINETIC VALVE MODEL CKV001

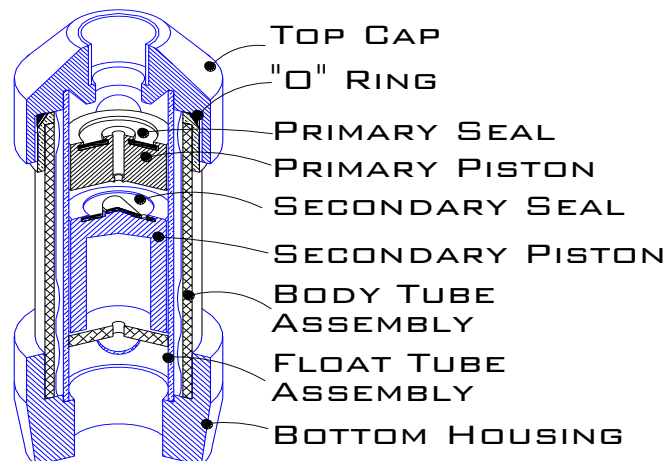

The CKV valve is supplied for filter Models up to MHS-3500 is known as a "Type A" and it is distinguished by the fact that it is supplied with a 40/20 Reducing Tee, 40mm Valve adaptor, 20mm to 1/2" BSP Faucet Elbow & 250kpa Pressure Gauge. Refer to Figure 8 for typical details.

When in operation the filter vessel will be under positive pressure and the pistons inside the CKV valve will "float" to vent any air that may be present within the filter. Once all the air has been effectively purged from the filter vessel, the flow from the valve will automatically cease. The valve will re-open each time that air enters the filter.

When the filter operation is interrupted (or the filter cycle is terminated) the piston inside the valve(s) will automatically "fall away" from the seal face to allow air to enter the vessel. As stated elsewhere, if the filter is located above the pool's operating water level, a Hartford loop in the filtered water return line should be used to prevent a full filter drain down. This "drain down" action will tend to pull solid contaminants deep into the filter bed and it will make them far more difficult to remove by normal backwashing.

Note that the 40mm valve adaptor must be screwed into the filters top bulkhead fitting in the same fashion as detailed in Section 11 (for the drain valve assembly). Use Teflon tape and hand tighten for a "snug fit". Note that the valve must be installed vertically with the 40mm connection at the bottom. It should be noted that in operation the CKV valve may "dribble" as it expels air from the filter or if the valve seats were to become fouled with foreign matter. The 1" BSP connection found at the top of the CKV Valve should be plumbed away from the filter,

preferably to the pool's balance tank or to a waste tundish with an appropriate air gap.

**Figure 8 – Typical Installation Chadson Kinetic Valve (Type A)**

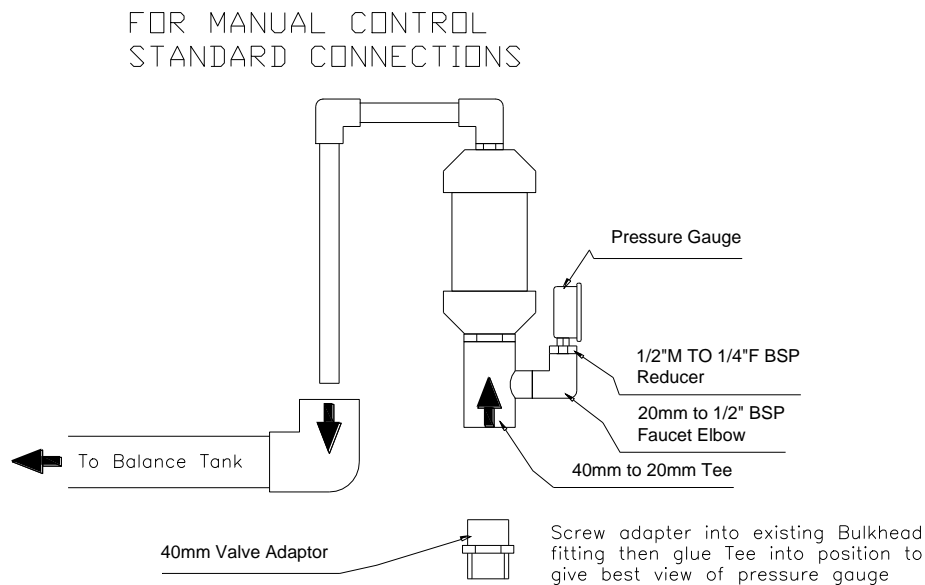

**WARNING !!**

The 1" BSP outlet of the CKV valve must NEVER be physically connected to the pump suction line, the return to pool line, or the backwash line. This will negate the primary functions of the CKV valve and it will void all filter warranty.

During the start-up and commissioning process, the installing Technician is required to verify the correct operation of the CKV Valve by visual inspection and reference to gauge readings. The clear body of the CKV valve will enable the air/water conditions to be easily monitored. Any abnormalities that are noted in either the start-up or shutdown procedures must be investigated immediately. If in any doubt contact your Authorized Service Centre for advice.

**13 LOADING THE FILTER MEDIA**

In many regards, the choice of filter media is as specified by a Consultant, or alternatively, it is a Client's choice. Apart from the wide range of conventional "sand" medias that are available, Chadson Granular Filters (CGF) can also be used for other processes that require the use "chemical type" filter medias such as granulated active carbon (GAC), etc., The required wash water rate (and the backwash procedure) for alternative filter medias should be established in accordance with the recommendations provided by the Supplier of the filter media.

When satisfied that all solvent welded (glue) joints have been made (and are fully cured) the filter can be filled with media. All face plumbing & connecting pipework should be completed prior to the media placement. Note that the drain valve assembly must also be installed (as in Section 11) before placing any filter media. Remember that once the filter media is placed inside the vessel, any re-work of the drain valve connection could require removal of the filter media.

The recommended procedure for media placement is as follows: -

- (a) Remove the Manhole cover(s) as described within Section 7.0

- (b) Partially fill the filter to cover the laterals with at least 150mm of water.
- (c) Carefully feed a substrate layer of 3mm gravel into the filter. This substrate layer should provide lateral coverage and it is designed to protect the underdrain system. If using a rake to spread this substrate, take care not to damage the filter's underdrain.
- (d) Continue to fill the filter with the required quantity of 16/30 filter sand.
- (e) The filter media should be raked out as level as possible. There should be no need to enter the vessel to place or level-out the media. Entry inside the vessel is subject to legislation (confined spaces) and special conditions. The filter bed will be automatically levelled during the filters first full backwash.
- (f) Clean around manhole, cover and seal and re-insert cover as described in Section 8. Do not over tighten the clamp nuts on the manway hatch. Make sure that the manway hatch is correctly and evenly seated.

In many industrial & water treatment applications it is necessary that the filter media be washed and sterilized prior to being placed into service. In these cases, the installing contractor should satisfy all specified requirements.

**WARNING !!**

Filter sand is predominantly a siliceous material and appropriate dust masks must be used in accordance with the supplier's Material Safety Data Sheets.

**14 HOW IT WORKS**

The primary function of a filter plant is to remove suspended solids. If these solids are not removed by filtration they will reduce the oxidizing power of the disinfection process and this will in turn, increase the need for further chemical treatment.

Whilst the removal of soiled particles by filtration is closely related to the function of disinfection, each of these functions makes an entirely different and distinct contribution to the maintenance of healthy pool water. In order to effectively manage a commercial swimming pool, these distinctions must be fully understood by the Pool Operator. Filtration will not necessarily solve a chemical problem, and vice versa.

Granular sand filters of all types perform their function of dirt removal by various principles, either singly or in combination with each other. The most apparent operating principle is a screening process where dirt particles are separated from the pool water on the basis that they are too large to pass through the openings of a granular filter bed.

Another filtration mechanism involves the removal of dirt particles by physical and electrochemical attraction. This mechanism can be enhanced with the controlled dose of a suitable coagulant. Properly applied, coagulants can assist the removal of turbidity, color, bacteria, algae, taste & odor producing substances.

More detailed information on "Filter Operation" can be found in Section 18.

## 15 FILTER BACKWASHING

Chadson Granular Filters are fitted with hydraulically balanced internals that are designed to provide laminar water flow in both the filter and the backwash cycle. Many filters in the CGF range distinguish themselves by being fitted with patented FloModuLatas™.

As the filter does its job of collecting impurities, the pressure drop across the filter will increase and the system flow will diminish. The filter is restored to its peak operating condition by backwashing or “reverse flow cleaning”. In this case, changing a filter into the backwash mode requires the operation of the single lever multiport valve that is supplied with the filter. When the single lever valve is set into a backwash mode, water enters the filter from the bottom of the filter vessel. This upward (reverse) flow expands the filter bed so that the collected matter breaks free, and washes out of the filter vessel to a point of disposal.

### NOTE !

Optimum filter performance is dependent upon regular and effective backwashing. Given that the specific requirements of each installation will vary, the installing contractor is required to establish and to record the optimum “backwash settings” as a fundamental part of the commissioning process. In this instance, the flow control valve found on the pump’s discharge is the principal mechanism to be adjusted.

The CGF “single lever multiport valve” is a simple but reliable mechanism that is designed to simplify the backwash process. It will also help to minimise the chance of operator error. When using the single lever backwash valve, it is important to remember the following: -

- (a) Before changing the multiport valve lever to either the “filter” or the “backwash” position, the pumping system should be shut down. Alternatively, the pump’s flow control valve (or the valve’s inlet isolating valve) must be fully closed. In other words, the multiport valve cannot be operated when water is flowing through the system. Refer to the “Warning” advice provided in Section 17.
- (b) After operating the valve lever, the pump should be restarted in accordance with the pump manufacturer’s instructions ie., with the pump’s flow control valve (or isolating valve on the inlet of the multiport valve) being gradually and slowly opened.
- (c) For the “filtering” position, the valve’s operating lever must be “locked-down” in the vertical plane. For the “backwash” mode, the valve’s operating lever must be “unlocked” and pulled outwards to its fullest extent.

### WARNING !!

Failure to effectively backwash individual filters will result in a cumulative build-up of solids that will detract from the efficiency of subsequent filter cycles. As detailed in Section 23, ineffective or infrequent backwashing will result in “reduced filter cycles” and generally poor water clarity. It is important to monitor the quality of the wash water on a regular/routine basis. A “dark brown” to “almost black” coloured wash water is commonly expected. If the wash water remains fairly clear (throughout the whole backwash cycle) the backwash operation is not effective and the conditions require urgent review and correction.

A cumulative build-up of collected solids (due to ineffective or infrequent backwashing) will quickly consume the pool’s residual chlorine that is required by State Health Departments. This cumulative build-up of solids also has the potential to corrupt filter beds and to create unwanted “chloramine” problems. As outlined in Section 22, corrupted/biological contaminated filter beds may require chemical cleaning and or complete replacement. By modern standards, the process treatment for indoor heated pools requires some form of advanced oxidation for effective “chloramine control”. The existence of “chloramines” is not a filtration problem.

## 16 START-UP PRE-REQUISITES



Competent Installers will start-up a new filter plant in accordance with an approved Check List that systematically tests, checks, and approves all individual components (and process operations) within the whole system. No attempt should be made to start-up a new filter system, until all the surrounding building works are truly completed and fully cleaned. The Installers start-up Check Lists should specifically address this requirement.

It is recommended that the intended water source be chemically tested to check for the presence of any high mineral or metal content before filling the pool. This knowledge may affect the possible start-up procedures and it could help to minimize the chance of staining the pool's interior. Many minerals & metal ions found in the source water will quickly oxidize when the pool is first chlorinated. Whilst this may be unavoidable, prior knowledge of this potential problem will enable the Installer to respond quickly. Materials that are oxidized by initial chlorination should be vacuum cleaned to waste as soon as practical.

The important pre-requisites for an effective start-up are as follows: -

- (a) Familiarise yourself with the location and function of all valves, pipes, and controls. If unfamiliar with any aspect associated with this plant do not proceed until an experienced technician is in attendance to manage and to witness the correct operation of the plant. If unsure, do not proceed.
- (b) Complete an electrical safety check and a full "name plate compliance" check (particularly on the pump).
- (c) It is not uncommon for considerable amounts of dirt and construction debris to remain after the construction phase. Once the pool and the surrounding decks have been totally completed, it is essential that all gutters, the pool itself, and the balance tank be thoroughly cleaned before filling the pool with water. Note that ammonia or phenol cleaning compounds must NOT be used in and around the pool.
- (d) Over fill the pool and super-chlorinate according to the instructions printed on the supply container. Leave the pool to settle for up to 24 hours, and then "vacuum clean" all the sedimentation "direct to waste", using a mobile vacuum cleaning cart. This will help to remove "unwants" and as such it will assist the initial treatment of the raw water.
- (e) Check that all gutter screens are in place. Check that the strainer basket is correctly seated inside the pre-pump strainer. The use of a suitable prepump strainer basket is a specific condition of warranty.
- (f) Check that the backwash detention tank is empty and that the wastewater pump-out system is operable.

As outlined below, the filter system should be started in the "filter" mode. This will ensure that any dirt, solids or foreign objects (in the suction piping system) will be retained by the filter media. By nature this will prevent the filter's underdrain from becoming needlessly blocked. The fine colloidal dust (that is common with new filter media) will not be retained by the filter media and it will be returned to the pool. This can be minimized by either washing the sand insitu or by installing a "filter to waste" connection. In this latter case, the filtered water line is connected and valved into the backwash line. If "fine dust" does return to the pool, let it settle on the pool's floor, and then vacuum clean it to waste using a mobile cleaning cart.

## **17 INITIAL START-UP**

### **Preliminary Work**

- (a) Make sure that all of the pre-requisites in Section 16 are fully satisfied and review all Notes & Warnings that are provided within these Instructions.
- (b) If the plant is located above the pool's true water level "prime" the recirculating pump by filling the pre-pump strainer with water. If below water level, secure the pre-pump strainer's lid, open all isolating valves, and open the vent on the strainer lid until such time that it is noted that the strainer is full of water. When a discharge of water is noted, close the strainer's air vent.
- (c) Set & double check the status of all valves as follows: -
  - All isolation valves on the suction side of the pump - "fully open"
  - Pump discharge valve - "fully closed".

- All isolation valves (for associated plant such as heating or chemical dosing) – “fully closed”
  - Both isolation valves on the inlet of the multiport valves – “fully open”
  - All valves on the “filtered water” side of the plant - “fully open”.
  - Both multiport valve(s) in the “lock down” position ready for initial filtering.
- (d) Double check that both filter drain valves are closed & that the Kinetic air release/vacuum breakers have been correctly installed.

**WARNING !!**

When operating the filter plant, it is important that all control valves be gradually opened and closed. Failure to do so could create “shock waves” and excessive surge (known as water hammer). Whilst the duration of this “water hammer” maybe quite short, it is capable of producing very high pressures that are capable of damaging the plant & equipment that is installed within the hydraulic system. Damage due to water hammer is not covered by product warranty. The use of “soft starters” and VSD controls (on your pumping system) are recommended as a means of obviating unnecessary water hammer. If these controls are not provided, satisfactory service can be readily obtained, providing that all valves are opened and closed slowly. Filters should not be automatically started by a time clock (or PLC) without the use of soft start or VSD.

**Initial Filter Operation**

- (e) Start the recirculating pump and gradually open the “flow control valve” found on the discharge side of the pump to about 75% open. As water is pumped through the system, the CKV valve will start to “work” by discharging trapped air (from the empty filter) direct to atmosphere. Note that the pressure gauge should also respond to the flow that is being applied through the filter. If the pump is equipped with VSD controls (or “soft start” provisions) the pump will slowly “ramp-up” to speed and in this case, the importance of using the flow control valve may be somewhat diminished. If the initial start-up pressure is more than 100kPa, shut down the pump(s) and review all conditions, including the status of all downstream (partially closed) valves. “Normal” conditions require a clean start up pressure in the order of 40 to 70 kPa. If this clean start-up pressure can not be provided, obtain advice before proceeding.
- (f) Satisfy yourself that water is flowing through the system as intended. If a “filter to waste” connection has not been provided, do not be alarmed if a considerable quantity of fine dust is returned to the pool. Once this dust settles, it can be readily vacuum cleaned direct to waste. Also look for any obvious water leaks indicating that some plumbing connections require repairs or replacement.
- (g) Run the filter plant for about ten minutes. This should ensure that any foreign objects and dirt in the system (and in the suction piping) will be successfully are retained by the filtering media. Note that the operation of the CKV valve will “settle down” and it will cease, as soon as all the air is purged from the system. If this does not happen, review the suction piping and look for defective joints and connections that could permit air to be drawn into the system under the pump’s vacuum.
- (h) After running the filters for ten minutes, slowly close the pump’s flow control valve and shut down the pump. Note that the piston in the CKV valve will “drop” and it allow air to enter the filter. The filter gauge will also return to its zero pressure reading. Resolve any abnormalities before proceeding.

**WARNING !!**

Do not attempt to operate the backwash valve with the pump running. This has the potential to cause serious damage & personal injury. If the pump is not shut down electrically, it is imperative that the pump’s “flow control valve” found on the discharge side of the pump be “fully closed”. For convenience, this flow control valve is sometimes located on the inlet to the single lever multiport valve (to act as an isolation valve). Notwithstanding any such detail, do NOT attempt to change the valve status when water flowing through the system.

**Initial Backwash Operation**

- (i) Before re-starting the pump, close the isolating valve on Filter F2 and move the multiport backwash valve on F1 into the “backwash position”. This is done by releasing locking lever at the top of the valve & pulling the main operating lever “out” to its fullest extent.
- (j) Restart the pump and gradually open the flow control valve found on the discharge side of the pump. This sets Filter F1 into “backwash”.
- (k) Backwash Filter F1 for as long as practical (say 4 to 5 minutes). If a sight glass is fitted in the backwash line, note that dirty water is being discharged into the backwash holding tank. Monitor the rising level in the backwash detention tank & reconfirm the operation of the wastewater pump. Note that the wastewater pump-out system may be governed by level and or time controls.
- (l) If practical, volumetrically assess the backwash flow into the BW tank, and adjust the pump’s flow control valve to ensure that the required backwash flow is being applied to the filter. (If this is not done down, it can always be done later, but the Installer must remember to ultimately commission & record the conditions that are necessary to achieve the correct backwash flow.)
- (m) Slowly close pump’s flow control valve and electrically shut down the pump. Note that the F1 filter gauge will drop to zero. When you become more familiar with these basic steps, there may be no need to shut down the pump electrically. With practise, a trained operator can comfortably work through the required “backwash steps” by simply closing the pump’s flow control valve. As outlined in your pump Manual, it does no harm to run the pump electrically (for about a minute) with the flow control valve fully closed. Once you are familiar with the procedures, this is more than enough time for simple valve changes.
- (n) With the pump still shut down, return the Backwash Valve on Filter F1 to the “filter” mode (i.e., push the operating lever towards the valve body and lock it in the down position) and close the isolation valve on this (F1) filter.
- (o) Open the isolating valve on Filter F2, and move the multiport backwash valve on the F2 filter into the “backwash position”. Again, you do this by releasing locking lever & pulling the main operating lever “out” to its fullest extent.
- (p) Re-start the pump and slowly open pump’s discharge valve in order to backwash Filter F2 in the same fashion as outlined for filter F1. Carefully proceed through all the steps and conclude with the F2 multiport valve in the “lock down filter” with isolation valve on the F2 multiport valve closed.
- (q) Shut down the recirculating pump & review your progress.

**NOTE !**

To obtain the best performance, you need to “sequentially” backwash the two filters that form this “tandem” system. This will help to minimize any preferential flows, with one filter doing most of the work. The system design should provide the required capacity for sequential backwashing.

**First Full Filter Cycle.**

- (r) With the suction lines purged by an initial filter cycle and both filters successfully backwashed, it time to start your first real filter cycle. With the recirculating pump off, review the plant settings, and open both isolating valves located on the inlet side of each multiport valve.
- (s) Re-start the pump, as previously outlined, and note that both filters are now in the normal “filter mode”. In particular note the “clean start-up pressure” of both filters. Subject to the nature of the piping system, these gauge readings should be approximately equal and somewhere between 40 to 70kPa. Also note that the pump’s vacuum gauge reading should register somewhere between - 20 to - 40 kPa. Investigate any abnormalities immediately. If in any doubt seek expert advice.
- (t) Commission the pump’s “flow control valve” to suit specific contract requirements and progressively bring on-line any associated plant (chemical dosing, heating plant, etc.) according to their specific Instructions. When the whole system is brought on-line some minor adjustments may be required to ensure compliance with the specified flow rate(s).

**NOTE !**

Be prepared that the commissioning process outlined in paragraph (t) may take some time. You may find that even minor adjustments, may affect previous settings. Work through these issues in a systematic way, checking and proving each adjustment that is made.

Subject to the quality of the source water, it may take several days to obtain the desired pool water quality.

### **Commissioning the Backwash Flow**

The installing Technician has a fundamental responsibility to ascertain all “conditions and the settings” that are necessary to ensure that the correct backwash flow is applied through each filter.

Whilst gauge readings and flow meters may be useful tool, the most reliable means of verifying the correct backwash flow is to calculate the volume of the backwash tank and to time “how” much wash water is pumped into the tank in say one minute. For example if the backwash tank were 4m x 4m, it would have a surface area of 16m<sup>2</sup>. If in one minute, the waste water level in the backwash tank rose by say 100mm, this would mean that backwash flow was 1600 litres/min (ie., 16m<sup>2</sup> x 0.1m = 1.6m<sup>3</sup> x 1000 = 1600 litres per minute or 27 l/sec). For this method to work, the wastewater pump must be shutdown or isolated. If this is not done, you will need to subtract the outgoing waste water flow in order to accurately assess the backwash flow.

## **18 FILTER OPERATION**

After the starting the filter system, an initial clean start up pressure will be displayed on the filter’s pressure gauge. Depending upon the nature of the system, this pressure should be in the range of 40 to 70 kPa. The initial “clean” start-up pressure should be recorded at the time of commissioning for the Operator’s future reference.

As the filter gets dirtier, the filter pressure will rise until it reaches a “terminal” level. At this point the filter is in its “dirtiest acceptable” condition and it should be backwashed. For normal use, the required pressure rise for backwashing should be considered to be 50 kPa above the “initial start up pressure”. If for example the initial start up pressure was 40 kPa, the filter should be backwashed when the pressure gauge indicates 90 kPa. If the clean start-up pressure was 60 kPa; backwashing should occur when a pressure of 110 kPa is reached.

Pool water treatment plants are customarily operated twenty-four hours per day. This practise is as much for mixing of the dirt load and the distribution of pool chemicals, as it is for the function of filtration. Routine filter duties should include monitoring of the CKV operation and monitoring all pressure gauge readings. If the filters are to be taken off-line for any length of time (eg., annual maintenance, or a winter shut down period) all filter vessels should be drained and vented. This is particularly important for chemical type filter media that adsorb impurities.

Given the construction materials used in the manufacture of CGF filters, filter beds may be effectively sterilized with sodium hypochlorite (and or other chemicals). An Authorized Service Agent should undertake this service type of service.

## **19 BACKWASH PROCEDURE**

Refer to the steps that were used for the initial backwash as in Section 17 and follow these procedures:-

- (a) When the pressure gauges indicate a “terminal head loss”, slowly close the pump discharge valve until virtually shut. If in any doubt, turn the pump off, electrically.
- (b) Isolate any downstream equipment that is dependant on flow from the filter system. This flow will not be available during the backwash process.

- (c) Set the “first filter to be backwashed” with the main lever on the single lever multiport valve in its raised backwash position. The isolating valve provided on the filter to be backwashed must be fully open, whilst the isolating valve on the other filter, should be fully closed.
- (d) Start the pump and slowly open the pump’s “flow control” valve until the required b’wash flow is obtained.
- (e) Backwash for up to 4 minutes or until the water runs clear. Note the “dirty waste water quality” through the recommended “flanged sightglass” or physically, within the backwash tank.
- (f) During the backwash cycle, check and monitor the operating levels in both the pool’s balance tank and the backwash detention tank. The operation of the pool’s “mains water make-up system” should also be checked at this time.
- (g) At the end of the first backwash cycle, slowly close the pump’s flow control valve until virtually shut. If in doubt, turn the pump off, electrically.
- (h) Return Backwash Valve to “filter” position and be sure to lock it in place.
- (i) Backwash the second filter in exactly the same manner as the first filter.
- (j) After successfully backwashing both filters, make sure that the multiport valves are in their lock down filter position and that the isolation valves on the inlet to each multiport valve are both fully open.
- (k) Slowly open the pump’s flow control valve (or start the recirculating pump, electrically) to commence another filter cycle. Note the reduction in filter operating pressures & record this data (with date & time of backwash) in the Operator’s Log Book.

Although the frequency of backwash is “load related” (as indicated by pressure gauge rise) CGF filters should be backwashed at least once a week.

As part of the commissioning process, the installing Contractor should establish a suitable timetable for regular backwashing. Whilst the normal backwash duration for sand filters should be 4 minutes, heavy bather loads could require longer and or multiple backwashes. Some high load applications may require backwashing every two to three days.

## **20 DISPOSAL OF WASH WATER**

Wash water from a pool water treatment plant is required to be discharged to sewer via a suitable backwash detention tank. Most local Authorities require that this backwash detention tank be sized to accept the total wash water consumption of the whole filter plant with an allowance for plant over-runs and solids sedimentation. Backwash tanks are best located so that the backwash lines from the filter are self draining.

To satisfy its basic design requirement, the backwash detention tank should be constructed with specific geometry that encourages sedimentation. Subject to specific site approvals, wash water from the backwash detention tank is discharged to sewer at a controlled rate (usually 2 l/sec) and at a specific time of day. These requirements will usually dictate the supply of various “controls” that will assist the Operator’s management of the plant. For example, level indicators in the backwash tank, could be used as the basis of confirming that adequate backwash storage capacity is available for the next backwash cycle.

It is imperative that backwash pump-out system be maintained in peak operating condition. The effectiveness of the filtration plant is totally dependent on regular and effective backwashes. In light of recent State & Federal initiatives, the beneficial re-use of wash water is strongly recommended. Refer to CGF for possible options.

## 21 OPERATOR'S DUTIES & RESPONSIBILITY

Once the installing contractor has commissioned the system, the Pool Operator is required to "operate and maintain" the plant in a safe and efficient condition. Apart from maintaining accurate records, it is important for the Operator to appreciate that: -

- The plant must be operated in strict accordance with the instructions and or recommendations that are given on start-up and or detailed within the Installing Contractor's Operational & Maintenance Manual.
- Pool water must be maintained and balanced in accordance with the Langelier Saturation Index with chemical concentrations as recommended by the relevant State Health Departments.
- The filter plant must be effectively backwashed according to a proven timetable that is adequate for the pools "true load/actual" conditions.

The fundamental maintenance requirements of a typical pool water treatment plant are as follows: -

- (a) Keep all work areas in a neat and orderly fashion.
- (b) Follow a systematic plan for the execution of the daily operations that are outlined within this Manual.
- (c) Routinely maintain the plant and its finishes.
- (d) Establish a routine schedule, whereby individual work areas or plant rooms are vigorously inspected. If problems or water leaks are discovered they must be reported and repaired as soon as they first become apparent.
- (e) Maintain meaningful records on all major items of plant. Apart from logging any repairs, record any unusual incidents or faulty operating conditions.
- (f) Observe all common sense safety measures.
- (g) Do not operate or tamper with equipment unless suitably trained & qualified.
- (h) At the end of each month, review all log sheets and test results and compile a summary of events.

### NOTE !

If an apparent defect occurs within the first twelve months of operation, its relevance and its significance could vary in importance. Be that as it may, the Pool Operator is required to notify the installing contractor of a possible problem (or any water leak) immediately it becomes apparent.

The Warranty provided with your Chadson Granular Filter does not relate to the system design, the installation, or any other items of associated plant and equipment that may be provided. Furthermore, the product Warranty does not allow for any failure to operate the product according to Instructions, or any form of abuse, water damage, negligence, and or accident. Refer to product Warranty details.

Prior to the expiry of the Installers' "defects maintenance period", the Owner/Operator is required to establish some form of Service & Maintenance Agreement with either the installing contractor or an Authorized Service Centre (ASC). Whilst these Agreements may take various forms (eg., periodic, predictive, corrective, preventative, etc.,) they are all designed to optimize the service life of your filter plant and to protect your rights to any "extended" warranty that may be provided.

Until such time, that is proven that the Operator's management is adequate, regular "microbiological testing" (by an approved NATA laboratory) is strongly recommended. Your regular test kit will not necessarily provide this type of confirmation. The source of microbiological contamination may vary. It may be carried into the pool by the bathers; it may be introduced into the pool via the make-up water; or it may come from other sources.

Due to the very low water velocity in many balance tanks or suction sumps, it should be noted that solids and sludge can progressively accumulate within these structures. Given their location in the process loop, the chlorine residual (inside these water-retaining structures) will customarily be quite low. In combination with warm

water temperatures, these conditions can provide an ideal environment for the growth of bacteria. Talk to your Authorized Service Agent regarding the need to periodically clean and desludge your balance tank/suction sump.

## 22 APPLICATION PROBLEMS

A typical pool water treatment plant will usually include various controls and devices that will assist the Operator's management of the filter plant. Failure to obtain a full system flow is usually indicated by gauge readings or a flow meter. If the filter's pressure gauge indicates a higher than normal pressure, one possible cause of this apparent high pressure could be contained within the filter.

After ascertaining the backwash conditions are correct and that the filter is being regularly cleaned (with the correct wash water rates) it may be necessary to take the filter off-line to inspect and manually rake the filter bed. If this operation is followed by an aggressive backwash, the normal filter pressures should then be restored. However, if the condition has proceeded too far (and if biological contamination has occurred) it may be necessary to scour the filter bed with a strong chlorine solution. In severe cases, it may even be necessary to replace the filter media. This work must be undertaken by an Authorized Service Centre (ASC).

It is important to note that granular filter beds can be corrupted in several ways: -

- (a) Premature start-up of the filter plant. If the recommendations provided within these Instructions are not observed and the filter system is started before all construction and finishing work has been truly completed, the life and the performance of the filter media will be seriously compromised. The short answer is not to start the filter plant until all building works are fully completed and thoroughly cleaned.
- (b) Calcification of the sand bed within a Chadson Granular Filter is not a common problem when the correct water balance is maintained and the backwash conditions are correct. However channeling of a filter bed can be caused by calcification or by scale that forms within a filter. In this situation, there may or may not be an indication on the pressure gauges, but there could be a noticeable by-pass of dirt through the filter. In this situation, poor water clarity would normally be symptomatic of the basic problem.
- (c) Another potential problem could be the formation of mud balls within the filter bed. This accumulation of mud, hair and lint can form into spheres that build up within the sand bed. They can best be removed using a proprietary cleaner to dissolve them to a point that they can be effectively removed by backwashing. As a last resort, replacement of the filter media may be necessary. The formation of mud balls within a filter is usually a management problem. In cases where the media classification is found to be smaller than normal tolerances, it is advisable to remove the top 20mm of media after the initial backwash operation. This will remove the small/undersize grain sizes that are largely responsible for the formation of mud balls. In this instance, the classification and grading of the filter media should be thoroughly checked. Using grades of filter sand that are finer than specified has the potential to create significant filter problems.
- (d) The above problems can also be related to the excessive use of chemical flocculants. Flocculants will never solve problems that are more correctly related to an over loaded or under-filtered pool; more often than not they will only exacerbate the problem. Flocculants should be used on a need basis and only then with a proper management reporting system. Changes to any trickle dose system should not be made without further reference to the installing Contractor.

To obviate the expensive maintenance that can be associated with the above problems, it is important to verify that backwash conditions are truly correct, and that the filter is being effectively cleaned. The best solution to prevent the above "problems", is to make sure that they do not happen in the first place.

Whilst "filter sand" is a semi-permanent media, it is generally considered to have a service life of about five to eight years. Excessive body oils and fats (common with indoor heated pools) will radically change the granular nature of a filter media. This also has the potential to "corrupt" a filter bed and to decrease the life of the filter

media. Be that as it may, regular and aggressive backwashing will ultimately change the shape and density of the sand grains to a point that the filter media needs replacement.

Used filter media is deemed to be a biological waste that is subject to specific disposal conditions. Talk to your Authorized Service Centre regarding the need for filter emptying and all sand replacements.

## 23 UNDERDRAIN DAMAGE

The filters underdrain will typically comprise a central header (or headers) with a given number of slotted laterals. The injection-moulded laterals provided in most models have downward facing slots with “v” shaped openings. As noted in Section 13, some care is required when first loading the filter media.

At some time during the life of the filter vessel, the filter laterals will require replacement. Under the general heading of “preventative maintenance” it is strongly recommended that new lateral sets be installed when periodically replacing the filter media. As outlined within AS-2865, the filter vessel is deemed to be a “confined space” that requires service personnel to have the appropriate certification.

Replacement of filter laterals is deemed to be “major service work” that should be undertaken by an Authorised Service Centre using genuine spare parts. For reference, the general arrangement of the filter underdrain is as follows: -

**Figure 9 – Typical Underdrain System**

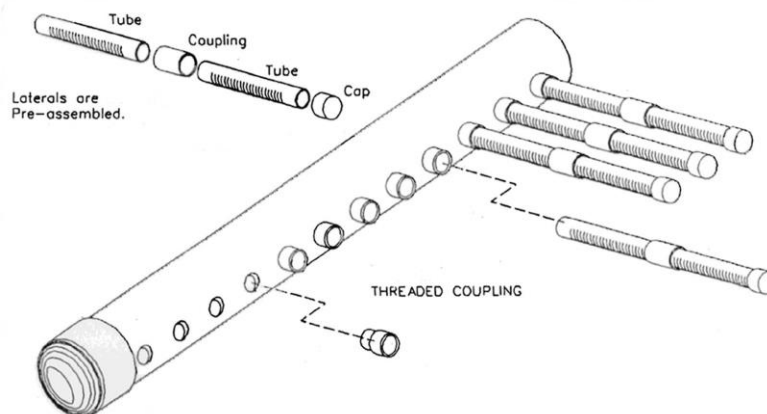

Note subject to the specific filter area provided by your Chadson Granular Filter, the detail and the arrangement of the underdrain system may vary according to filter’s model number.

## 24 PROBLEM SOLVING

If your filter does not perform to your complete satisfaction, we ask you review the circumstances that are associated with the problem. In many cases an apparent problem can often be resolved with simple reasoning. If other non-related products are connected into the filter circuit, it is necessary to ascertain that this equipment has been installed and operated according with that manufacturer’s instructions.

### Lack of Water Clarity

Incorrect pool chemistry – check and adjust chemical levels



Soiled water has high air content – fix suction leak & ensure that air vent is operable
Insufficient running times, insufficient backwashing – run longer, backwash more often
Check filter bed for channelling & review possible causes – correct conditions
High bather loads - manage bather load to suit available plant capacity
High water temperatures – do not operate at higher than intended temperatures
Inadequate flow/poor recirculation – check pump selection & system design
Insufficient filter area – review filter selection
Colloidal material passes through the filter – flock the pool & vacuum clean all sediment to waste

### Low Water Flow

Check the pump's vacuum gauge reading - ideally it should be between -20 to -40kpa
Check the pre-pump strainer for collected debris - clean the filter basket
Check for restriction of blockage in both the suction or the return lines
Filter is blocked – review backwash procedures & backwash conditions.
Pool water level too low - inadequate supply water, pump not fully primed
Pump requires service; check rotation, internal blockage, worn parts, etc.,
Pump operating under speed – check for low voltage etc.,
Pump not performing to specifications - review pump gauge readings

### Short Filter Cycles

Check chlorine content & adjust as required
Poor water chemistry - check pH and total alkalinity
Excessive pump flow - check performance and pump selection
Filter not being regularly backwashed
Ineffective backwashing - check conditions & ensure adequate backwash flow
Excessive use of chemical flocculants

### High Pressure on Start-Up

Poorly planned or undersized return piping
Insufficient return nozzles or adjustable nozzles excessively restricted
Partially closed valve on the filtered water return line - review valve status
Faulty pressure gauge - replace and review pressures
Check correct installation & operation all equipment installed downstream of the filter
Over-sized pump - check pump selection, review gauge & flow readings
Filter is dirty - needs effective backwashing.

### Filter Media Returning To Pool

Check that it is “filter sand”, not dirt from another unknown source.
Inspect filter bed for local depression (indicating a broken lateral) – refer Service Agent
Broken Lateral (upon start-up) – Possible transport damage or broken during the placement of filter media
Broken Lateral (after use) – Possible application problems (mud ball problem). Review conditions.

## 25 BACKWASH VALVE – TROUBLE SHOOTING GUIDE

PROBLEM	CAUSE	REMEDY
Water continues to flow from	Dirt trapped between Piston and	Keep pump running fully and slightly open

Backwash line when valve is closed after a backwash sequence.	Seat.	the backwash valve by about <b><u>3 mm. Max.</u></b> This should flush out any dirt lodged between Piston & Seat. After a few seconds shut the Backwash Valve and <b>LOCK</b> into position.
Ditto.	Operating Lever not locked in position.	<b>LOCK</b> Operating lever into 'Filter' position.
Ditto	Damage to the Piston or seat.	Change the Piston assembly or Seat.
Water leaks from Shaft Gland.	Gland seal Packing material over compressed or damaged.	Tighten Gland Nut and if leakage does not stop, change gland-packing material.
Valve jams during movement from one position to the other.	Debris trapped between Piston and valve body.	Agitate the valve lever to dislodge the debris. If this fails open up valve and manually remove the debris.

## 26 AIR RELEASE, VACUUM BREAKER – TROUBLE SHOOTING

The operation of the Air Release & Vacuum Breaker Assembly should be checked on a daily basis.

PROBLEM	CAUSE	REMEDY
Air is constantly visible in barrel of the kinetic valve assembly.	Air ingress from the plant's suction lines.	Check Suction lines, Hair & Lint Strainer seals and pump shaft gland for air ingress. Seal any leak found using manufacturers approved methods.
Water is leaking from the Kinetic Valve.	Dirt Entrapment in valve seal.	Shut down filter for about 30 seconds and re-start. Dirt should be washed out and seal achieved. If this fails, order a replacement kinetic valve from your Authorized Service Agent. .
No Pressure on Pressure Gauge	Blocked Gauge orifice.	Shut down filter, remove gauge and clean our orifice.
Ditto.	Pressure Gauge Failed.	Shut down filter, remove gauge and replace.
Pressure Gauge giving incorrect reading	Ditto.	Ditto.

### WARNING !!

On no account should a filter be operated without an effective air vent, vacuum breaker, or pressure gauge.

## 27 WATER CHEMISTRY GUIDE LINES

Whilst relevant State Health Authorities have specific requirements (that must be maintained) the following table is provided as simple over-view of the basic water quality requirements necessary for successful pool operation.

Parameter	Range	To Raise	To Lower
pH	7.2 to 7.6	Add soda ash	Add muriatic acid or equal
Total Alkalinity	80 to 100 ppm	Add sodium bicarb	Add muriatic acid
Chlorine (unstabilised)	0.6 to 1.0ppm	Add chlorine	No action - will dissipate
Chlorine (stabilized)	1.0 to 1.5ppm	Add chlorine	No action - will dissipate
Stabilizer (cyanuric acid)	25 to 75ppm	Add stabilizer	Dilute - partially drain & refill
TDS	(max 1500ppm)	Not applicable	Dilute – partially drain & refill



**NOTE !**

Whilst the Information provided within these Instructions is the best available at the time of publication, it may be subject to future change or periodic revisions. Fulham Engineering Services Pty Ltd & Chadson Granular Filter Systems assumes no responsibility for the use of this information. It is the Installers and the Operator's responsibility to obtain and to check all current specifications and requirements prior to undertaking any work, procedure, and or revision.

**27 ADDENDA**

Use this section for the addition of related information such as CGF Data Sheet, Variations to the Supply Contract, MDR (Certified Test Sheets), Change Notes, project specific engineering drawings, etc.,