



CHADSON GRANULAR FILTERS

SERVICE INSTRUCTION SHEET

DATE: MAY 06 REVISION: B DOC #: 114

PG 1/4

TITLE: MAINTENANCE OF CHADSON MULTIPORT VALVE

PARTS IDENTIFICATION:

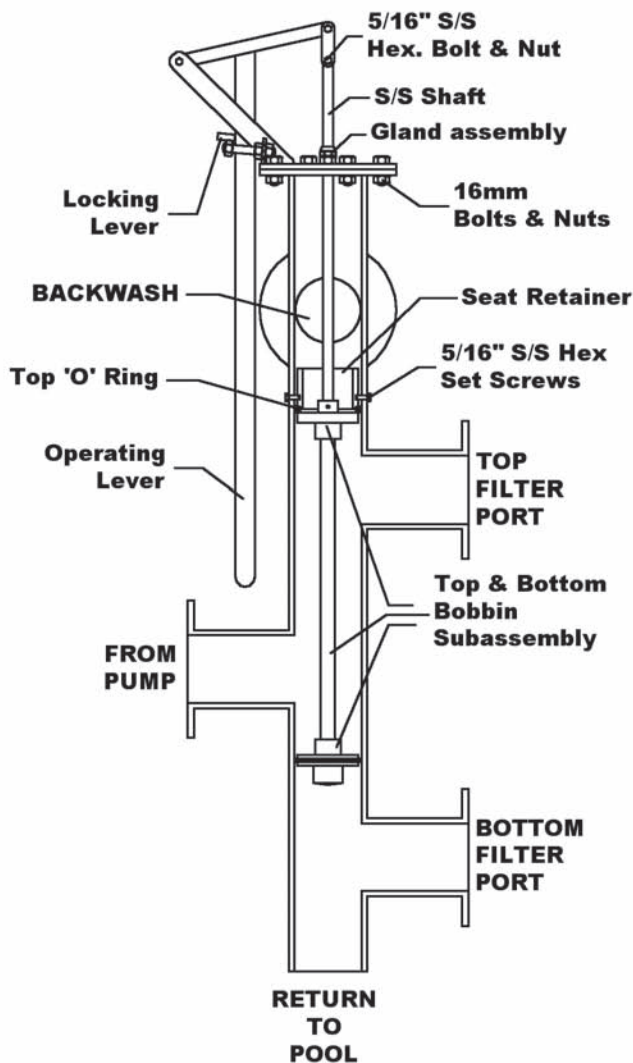

Tools Required:

Spanners for 5/16" & 16mm Bolts.

Ø6mm Steel Rod [or Phillips Screwdriver].

Mallet.

Hammer.

Cold Chisel.

Pin Punch.

Length of Plastic or Wood [to reach Seat Retainer].

Length of Ø3mm Wire [to hook out Top "O" Ring].

Dish washing liquid.

NOTE:

IF HEADROOM IS INSUFFICIENT, IT MAY BE NECESSARY TO REMOVE VALVE ASSEMBLY FROM FILTER BEFORE PROCEEDING WITH MAINTENANCE.

1

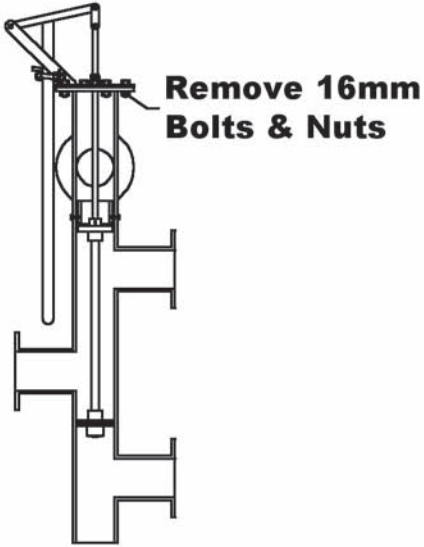

2

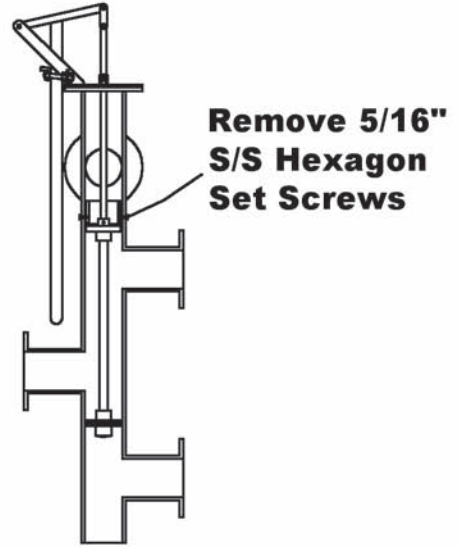

3



4



5



6

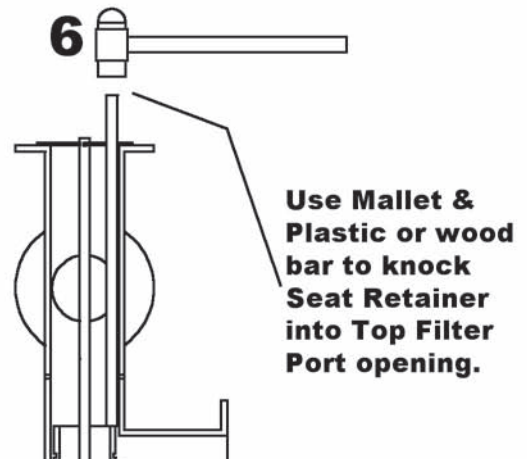

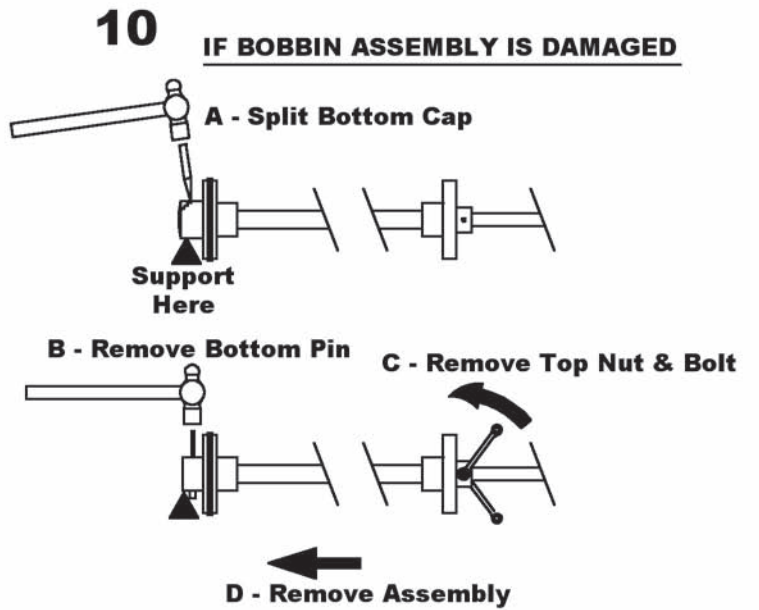
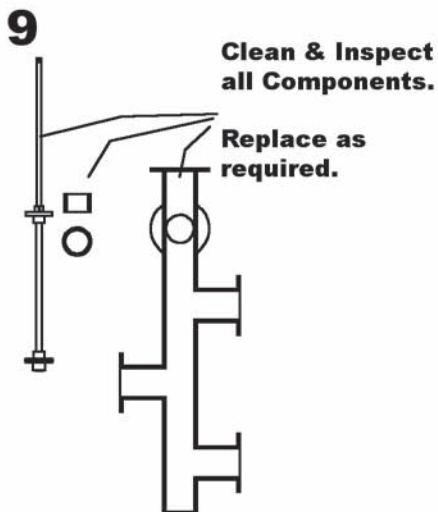
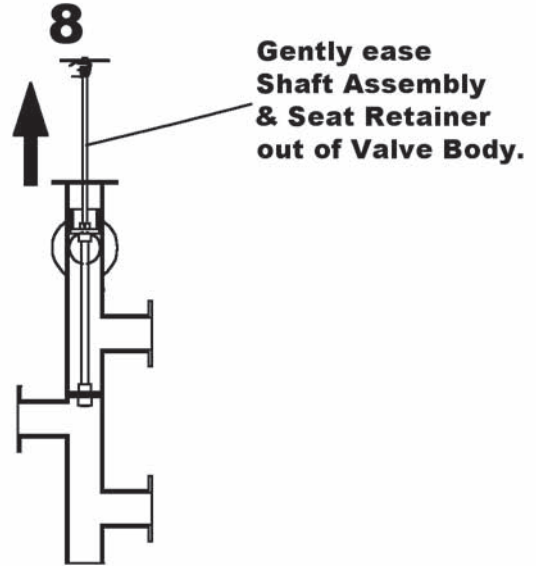
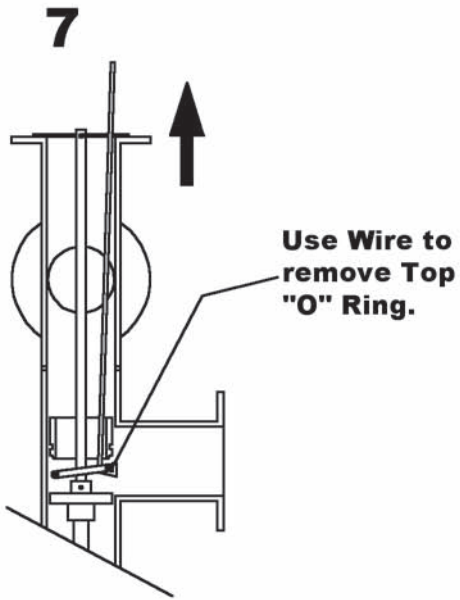

11 BOBBIN ASSEMBLY RE-FITTING

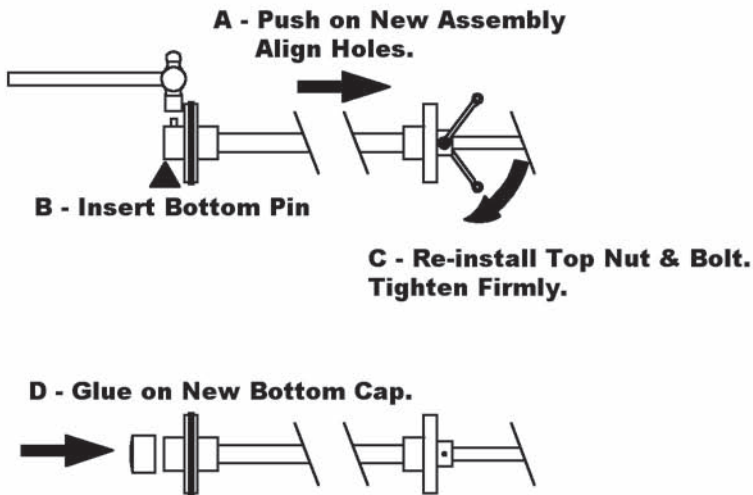

12

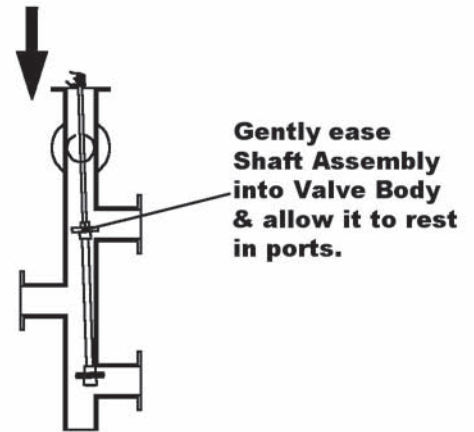

13

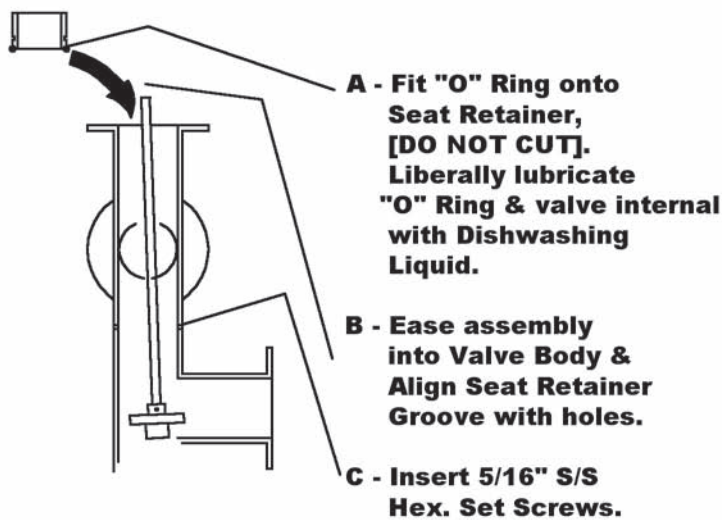

14

